

60" Ø GATE WELL ASSEMBLY WITH FLEXIBLE CONNECTORS

APPROVED BY: _____
 COMPANY: _____
 DATE: _____

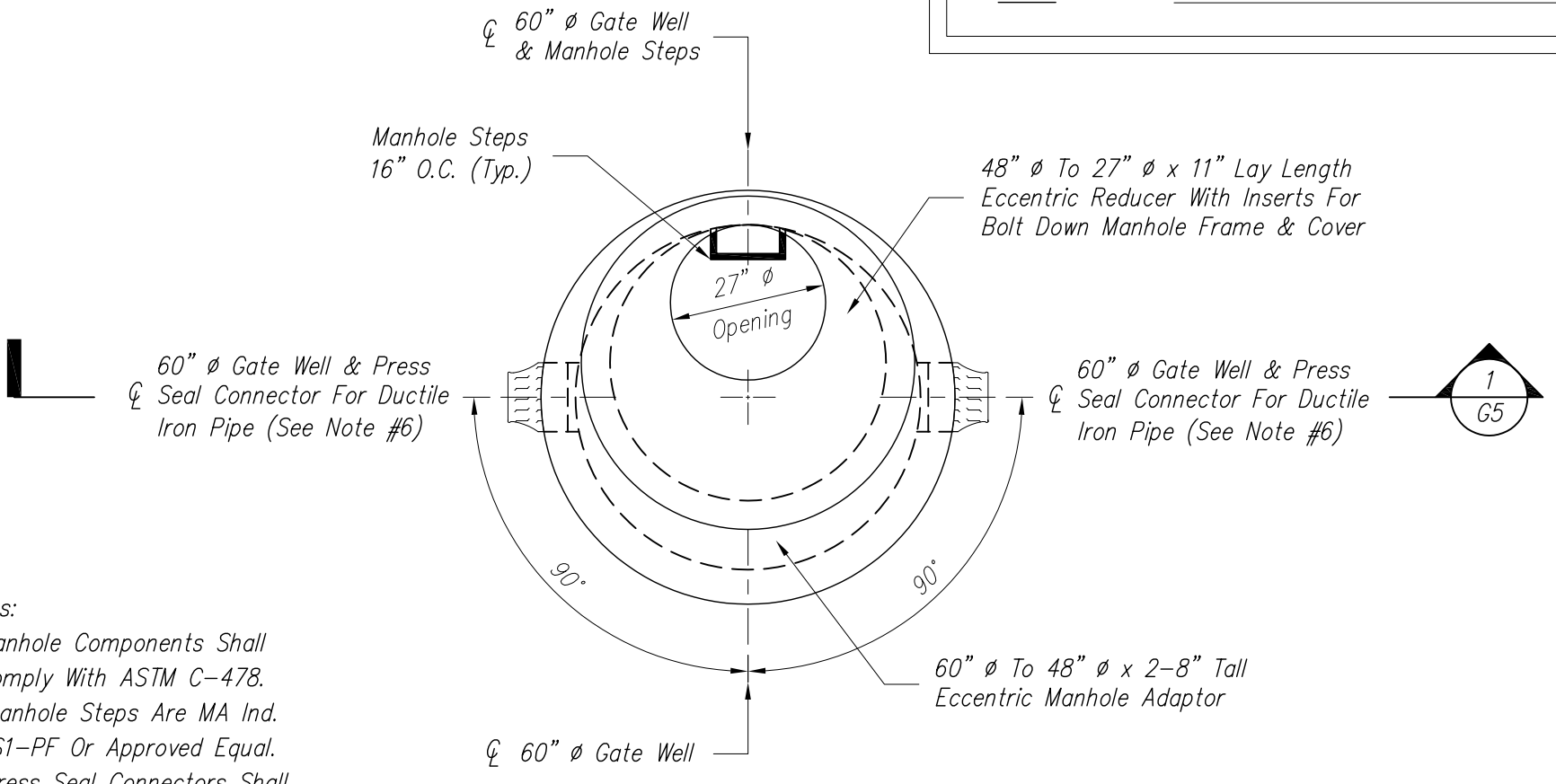

- Notes:
1. Manhole Components Shall Comply With ASTM C-478.
 2. Manhole Steps Are MA Ind. PS1-PF Or Approved Equal.
 3. Press Seal Connectors Shall Comply With ASTM C-923.
 4. Minimum Concrete Compressive Strength Shall Be 4,000 p.s.i.
 5. See 60" Ø Base Section Table For Other Commonly Available 60" Ø Base Section Heights.
 6. See Press Seal Connector Chart For Watermain Diameter And Pipe To Manhole Connector Models.

PLAN VIEW

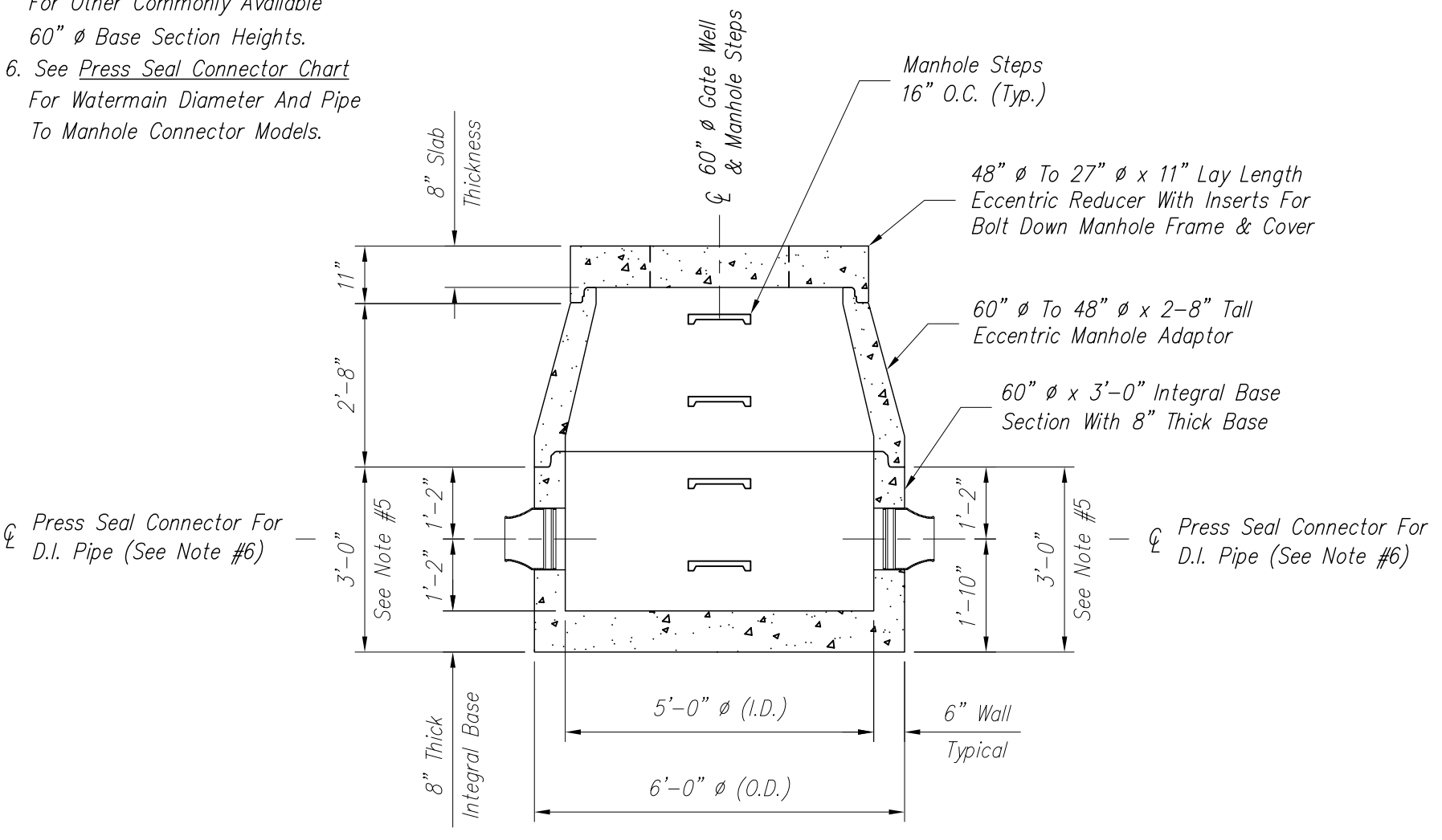

1 SECTION
G5

Press Seal Connector Chart	
Watermain Diameter	Model #
3" Ø D.I.	8QRS PSX:DD
4" Ø D.I.	8QRS PSX:DD
6" Ø D.I.	12-06 PSX:DD
8" Ø D.I.	12-11 PSX:DD
10" Ø D.I.	16Y PSX:DD
12" Ø D.I.	16M PSX:DD

60" Ø Base Section (Height)	
3'-0" (Std.)	
4'-0"	
5'-4"	

Joint Type	
ASTM C 443	

Approximate Component Weights:
 60" Ø x 3'-0" Integral Base Section..... 6,225#
 60" Ø To 48" Ø x 2'-8" Eccentric Adaptor.... 3,275#
 48" Ø To 27" Ø x 11 Eccentric Reducer..... 2,000#

Drawing No. _____
 Drawn By: RLH
 Scale: 1=30
 Sheet No. G5
 Chk'd By: JKC
 Date: 11/29/05

**60" Ø GATE WELL
ASSEMBLY WITH
FLEXIBLE CONNECTORS**

Sheet Title:
 PLAN & SECTION VIEWS
 Producer:
 THE PREMARC CORPORATION

Revisions:	
No.	Date
1	
2	
3	
4	

PREMARC
 INFRASTRUCTURE SPECIALISTS SINCE 1927
 7505 Highway M-71
 Durand, Michigan 48429
 (989)-288-2661